



PU204

TTL / RS422 - HTL converter & direction signal generator without potential separation

Product Features:

- Converts TTL / RS422 signals (A, /A, B, /B, Z, /Z) to HTL with 10 ... 30 VDC level
- Generates also a static HIGH / LOW direction signal or separate direction-pulses from a directional 90° phase shifted A / B information
- Open PCB version with plastic-housing for a simple snapping onto top hat rails according to EN 60715
- Input frequencies up to 200 kHz possible
- 10 ... 30 VDC power supply

Version:	Description:
PU20402a/ June-07/hk	First edition format A5
Pu202_02b/Oct-15/ag	- Safety Instructions and “Technical Specifications” updated - Design updated and “Legal notices” supplemented - New sub-chapter (2.1) for pulse diagram
Pu204_02c_oi/Apr-16/ag	Version jump due to small text correction in the German version

Legal notices:
All contents included in this manual are protected by the terms of use and copyrights of motrona GmbH. Any reproduction, modification, usage or publication in other electronic and printed media as well as in the internet requires prior written authorization by motrona GmbH.

Table of Contents

1.	Safety Instructions and Responsibility	3
1.1	General Safety Instructions.....	3
1.2	Use according to the intended purpose.....	3
1.3	Installation	4
1.4	Cleaning, Maintenance and Service Notes.....	4
2.	Introduction	5
2.1.	Pulse diagram	5
3.	Construction and Dimensions.....	6
4.	Power Supply	7
5.	Setting of the Direction Signal.....	8
5.1.	Indication of direction by phase displacement (quadrature pulses).....	8
5.2.	Indication of direction by static direction output.....	8
5.3.	Separate channels for forward and reverse pulses.....	8
6.	Connection of the Impulse Input	9
6.1.	Where at the input you use a shaft encoder which needs to be supplied by the PU204 unit:	9
6.2.	Where you use an encoder with separate supply, or the encoder simulation of a drive ..	9
6.3.	Where you like to use fully differential mode	9
7.	Technical Specifications.....	10

1. Safety Instructions and Responsibility

1.1 General Safety Instructions

This operation manual is a significant component of the unit and includes important rules and hints about the installation, function and usage. Non-observance can result in damage and/or impairment of the functions to the unit or the machine or even in injury to persons using the equipment!

Please read the following instructions carefully before operating the device and observe all safety and warning instructions! Keep the manual for later use.

A pertinent qualification of the respective staff is a fundamental requirement in order to use these manual. The unit must be installed, connected and put into operation by a qualified electrician.

Liability exclusion: The manufacturer is not liable for personal injury and/or damage to property and for consequential damage, due to incorrect handling, installation and operation. Further claims, due to errors in the operation manual as well as misinterpretations are excluded from liability.

In addition the manufacturer reserve the right to modify the hardware, software or operation manual at any time and without prior notice. Therefore, there might be minor differences between the unit and the descriptions in operation manual.

The raiser respectively positioner is exclusively responsible for the safety of the system and equipment where the unit will be integrated.

During installation or maintenance all general and also all country- and application-specific safety rules and standards must be observed.

If the device is used in processes, where a failure or faulty operation could damage the system or injure persons, appropriate precautions to avoid such consequences must be taken.

1.2 Use according to the intended purpose

The unit is intended exclusively for use in industrial machines, constructions and systems. Non-conforming usage does not correspond to the provisions and lies within the sole responsibility of the user. The manufacturer is not liable for damages which has arisen through unsuitable and improper use.

Please note that device may only be installed in proper form and used in a technically perfect condition - in accordance to the Technical Specifications (see chapter 7). The device is not suitable for operation in explosion-proof areas or areas which are excluded by the EN 61010-1 standard.

1.3 Installation

The device is only allowed to be installed and operated within the permissible temperature range. Please ensure an adequate ventilation and avoid all direct contact between the device and hot or aggressive gases and liquids.

Before installation or maintenance, the unit must be disconnected from all voltage-sources. Further it must be ensured that no danger can arise by touching the disconnected voltage-sources.

Devices which are supplied by AC-voltages, must be connected exclusively by switches, respectively circuit-breakers with the low voltage network. The switch or circuit-breaker must be placed as near as possible to the device and further indicated as separator.

Incoming as well as outgoing wires and wires for extra low voltages (ELV) must be separated from dangerous electrical cables (SELV circuits) by using a double resp. increased isolation.

All selected wires and isolations must be conform to the provided voltage- and temperature-ranges. Further all country- and application-specific standards, which are relevant for structure, form and quality of the wires, must be ensured. Indications about the permissible wire cross-sections for wiring are described in the Technical Specifications (see chapter Z).

Before first start-up it must be ensured that all connections and wires are firmly seated and secured in the screw terminals. All (inclusively unused) terminals must be fastened by turning the relevant screws clockwise up to the stop.

Overvoltages at the connections must be limited to values in accordance to the overvoltage category II.

For placement, wiring, environmental conditions as well as shielding and earthing/grounding of the supply lines the general standards of industrial automation industry and the specific shielding instructions of the manufacturer are valid. Please find all respective hints and rules on www.motrona.com/download.html --> “[General EMC Rules for Wiring, Screening and Earthing]”.

1.4 Cleaning, Maintenance and Service Notes

To clean the front of the unit please use only a slightly damp (not wet!), soft cloth. For the rear no cleaning is necessary. For an unscheduled, individual cleaning of the rear the maintenance staff or assembler is self-responsible.

During normal operation no maintenance is necessary. In case of unexpected problems, failures or malfunctions the device must be shipped for back to the manufacturer for checking, adjustment and reparation (if necessary). Unauthorized opening and repairing can have negative effects or failures to the protection-measures of the unit.

2. Introduction

PU204 is designed to convert impulse levels from a TTL or RS422 format to a 10...30VHTL format. At same time, the unit is suitable to convert the information of direction from the quadrature format to other usual standards like shown in the pulse diagram below.

2.1. Pulse diagram

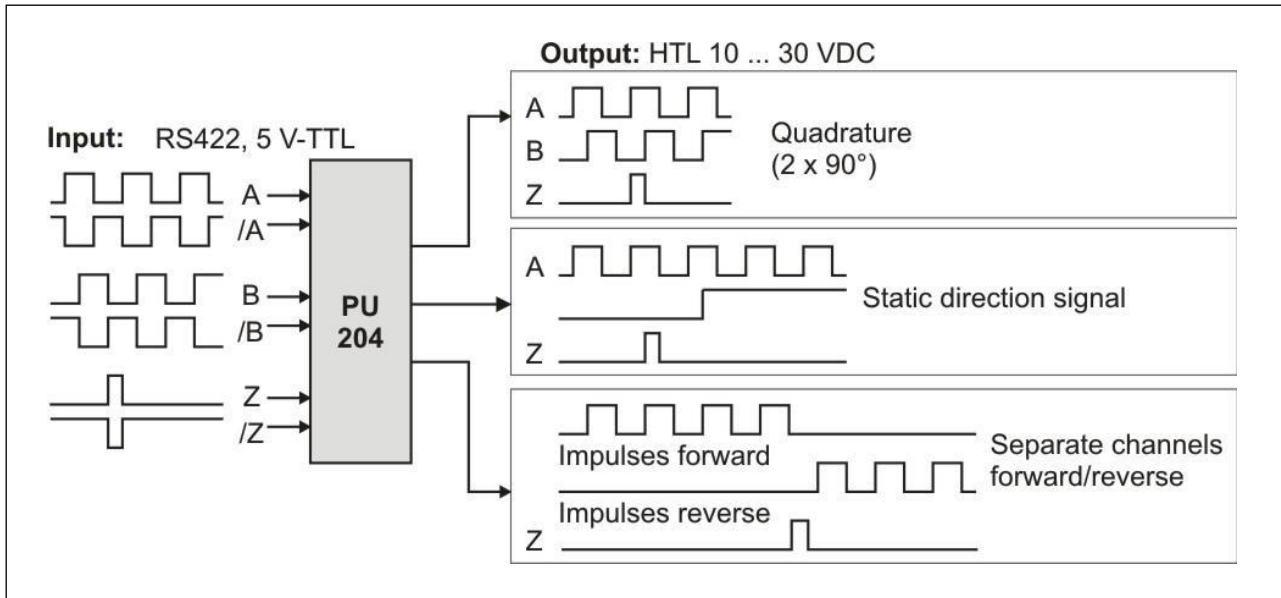

For vice-versa conversion of level and direction signal, see type PU202.

3. Construction and Dimensions

The unit is designed as a PCB with a plastic frame for direct and easy DIN rail mounting. The impulse inputs are available on a 9-pin SUB-D-connector (male).

The outputs are available on a 9-pin SUB-D-connector (female). For power supply of the unit and of encoders, two 3-position screw terminals are available.

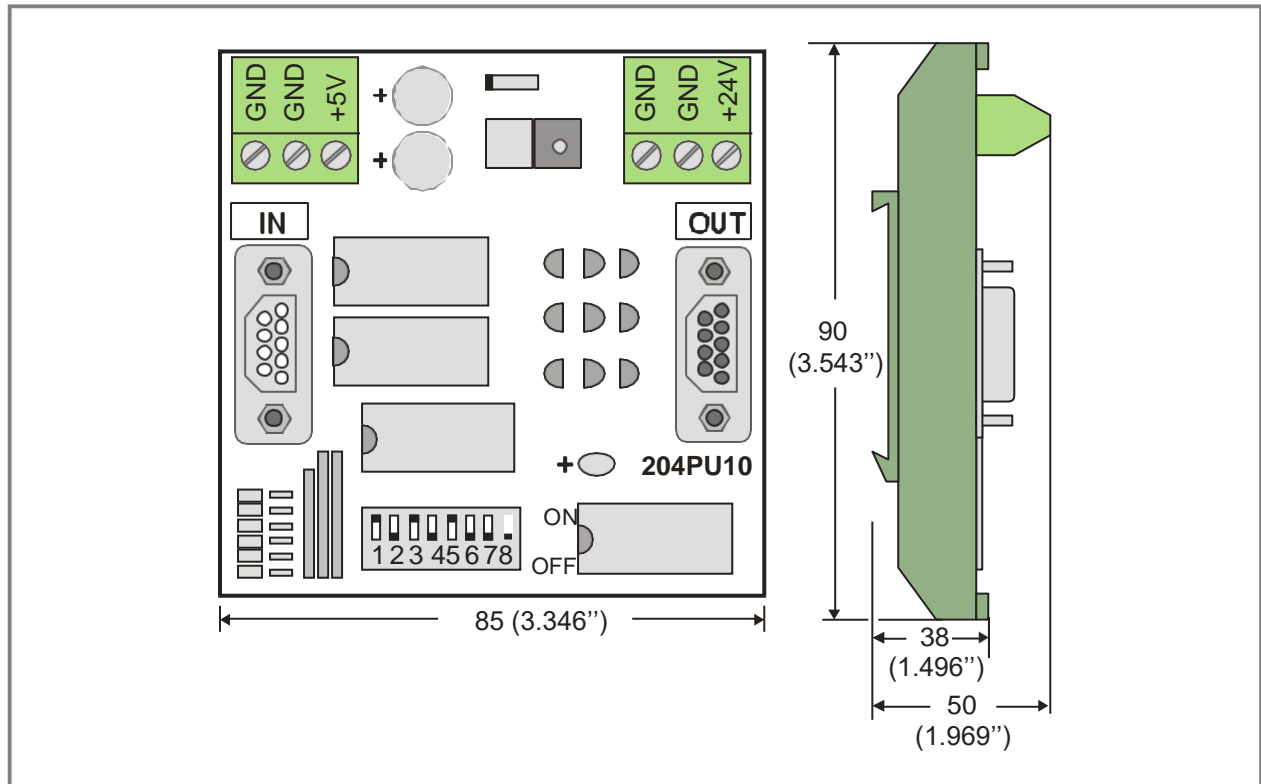

4. Power Supply

The unit needs a 10 ... 30 VDC supply. The level of the supply voltage automatically determines also the level of the output swing (24V supply will cause pulse output with 24V level also). The supply voltage can either be applied to the screw terminals marked “GND” and “+24V”, or also via the female SUB-D-9 output connector, using pin 5 (GND) and pin 4 (+24 V).

For encoder supply, an auxiliary voltage of +5 V / 100 mA at pin 4 of the input connector (SUB-D-9 male) can be made available. This voltage can also be taken from the screw terminal marked “+5V”.

For use of the +5 V auxiliary voltage at the input connector or the screw terminal, you must set position 7 and 8 of the 8 pole DIL switch to “ON”.



Warning!

Never, with DIL switch position 7 and 8 “ON”, any external voltage must be applied to input connector pin 4 or to screw terminal marked “+5V”! This would cause irrevocable damage to the unit!

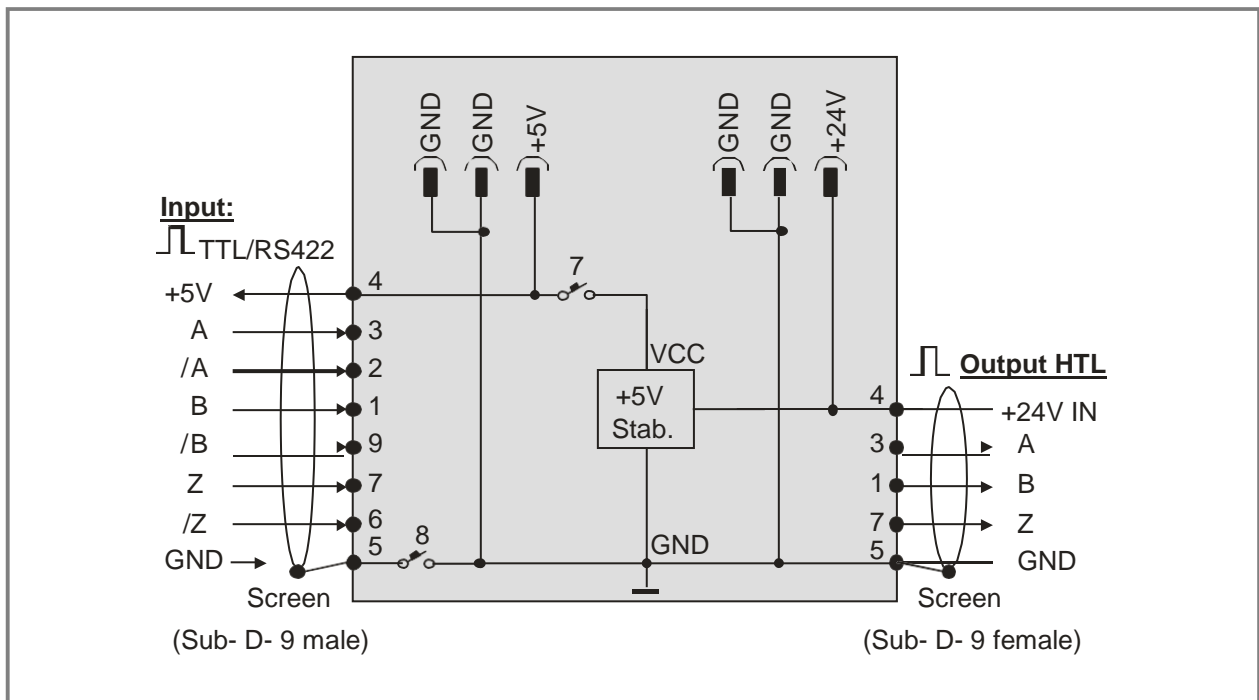

5. Setting of the Direction Signal

The unit, at the output, can use three different modes to indicate the sense of rotation. Output modes can be selected by the 8-position DIL switch on the print:

5.1. Indication of direction by phase displacement (quadrature pulses)

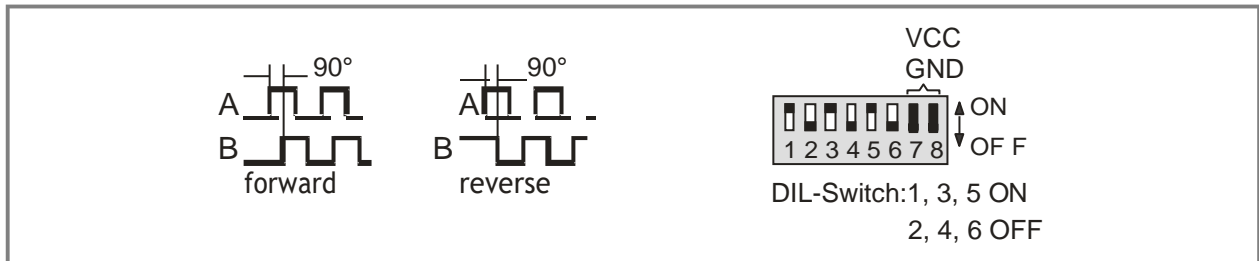

5.2. Indication of direction by static direction output



5.3. Separate channels for forward and reverse pulses

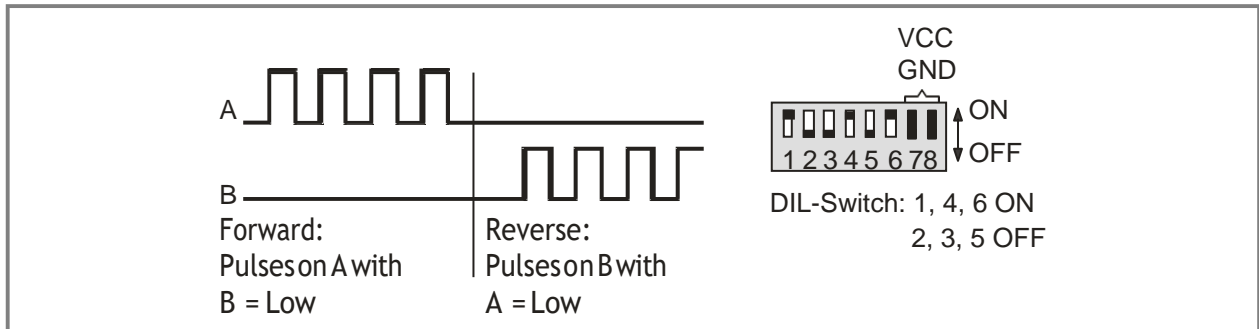

6. Connection of the Impulse Input

6.1. Where at the input you use a shaft encoder which needs to be supplied by the PU204 unit:

- Set DIL-switches 7 + 8 to “ON”.
- Supply the encoder from pins 4 and 5.
- Connect the screen to the supply minus wire at the PU204 side (pin 5).

6.2. Where you use an encoder with separate supply, or the encoder simulation of a drive:

- Set DIL-switch 7 to “OFF”, 8 to “ON”.
- Connect the screen to GND pin 5 on the PU204 side.

6.3. Where you like to use fully differential mode:

- Connect only the impulse lines.
- Set DIL-switch 7 to “OFF”, 8 to “ON”.
- Connect the screen to GND pin 5 on the PU204 side.

7. Technical Specifications

Power supply:	Input voltage: Protection: Ripple: Consumption: Connections:	10 ... 30 VDC reverse polarity protection and fuse (0, 315 A medium time lag) ≤ 10 % approx. 85 mA (unloaded) selectively by 1.5 mm ² / AWG 16 screw terminal or 9-pin female SUB-D connector
Encoder supply:	Output voltage: Connections:	5 VDC / max. 100 mA (switchable) selectively by 1.5 mm ² / AWG 16 screw terminal or 9-pin male SUB-D connector
Inkremental input:	Levels: Channels: Frequency: Connections:	5V-TTL / RS422 A, /A, B, /B, Z, /Z max. 200 kHz male SUB-D connector, 9-pin
Inkremental output:	Levels: Output logic: Channels: Output current: Signal delay time: Connections:	HTL (10... 30 V, depending on supply voltage) push-pull A, B, Z max. 30 mA per channel approx. 800 ns female SUB-D connector, 9-pin
Housing:	Material: Mounting: Dimensions (w x h x d): Protection class: Weight:	plastic 35 mm tophat rail (according to EN 60715) 78 x 90 x 70 mm / 3.071 x 3.543 x 2.756 inch IP20 approx. 100 g
Ambient temperature:	Operation: Storage:	0 °C ... +45 °C / +32 ... +113 °F (not condensing) -25 °C ... +70 °C / -13 ... +158 °F (not condensing)
Failure rate:	MTBF in years:	83.1 a (long-term usage at 60 °C / 140 °F)
Conformity & standards:	EMC 2004/108/EC: Guideline 2011/65/EU:	EN 61000-6-2, EN 61000-6-3, EN 61000-6-4 RoHS-conform