



GV204

Impulse Splitter for Incremental Encoders

Product features:

- Programmable encoder input A, /A, B, /B, Z, /Z, for use with RS422 or TTL differential signals or with HTL signals (differential or single-ended)
- Two encoder outputs (A, /A, B, /B, Z, /Z each) with individually programmable output levels (TTL 5 V or HTL 10 to 30 V)
- Max. frequency 750 kHz (TTL) or 300 kHz (HTL)
- Power supply either 5 VDC or 10 to 30 VDC
- Aux. voltage output +5V for encoder supply (with 10 to 30 VDC power supply)

Version:	Description:
GV20401a/af/hk_Sept08	First edition
Gv20401b/ag/Apr. 15	Some modifications. Safety Instructions & Technical Specifications renewed.
Gv204_01c_oi/Apr-16/ag	DIL-Setting = HTL in case of 5V supply via +Vext. Modifications and additions were made in the block diagram, note boxes and in chapter „Impulse Outputs“.

Legal notices:
All contents included in this manual are protected by the terms of use and copyrights of motrona GmbH. Any reproduction, modification, usage or publication in other electronic and printed media as well as in the internet requires prior written authorization by motrona GmbH.

Table of Contents

1. Safety Instructions and Responsibility	3
1.1. General Safety Instructions	3
1.2. Use according to the intended purpose	3
1.3. Installation	4
1.4. Cleaning, Maintenance and Service Notes	5
2. Compatibility Hint	6
3. Application	6
4. Block Diagram	7
5. Power Supply	8
5.1. Supply via +VB from an unstabilized 10 ... 30 VDC source	8
5.2. Supply via +Vext from a stabilized +5 VDC source	8
6. Impulse Inputs	9
7. Impulse Outputs and Output Levels	10
8. Dimensions	11
9. Technical Specifications	12

1. Safety Instructions and Responsibility

1.1. General Safety Instructions

This operation manual is a significant component of the unit and includes important rules and hints about the installation, function and usage. Non-observance can result in damage and/or impairment of the functions to the unit or the machine or even in injury to persons using the equipment!

Please read the following instructions carefully before operating the device and observe all safety and warning instructions! Keep the manual for later use.

Appertinent qualification of the respective staff is a fundamental requirement in order to use these manual. The unit must be installed, connected and put into operation by a qualified electrician.

Liability exclusion: The manufacturer is not liable for personal injury and/or damage to property and for consequential damage, due to incorrect handling, installation and operation. Further claims due to errors in the operation manual as well as misinterpretations are excluded from liability.

In addition the manufacturer reserve the right to modify the hardware, software or operation manual at any time and without prior notice. Therefore, there might be minor differences between the unit and the descriptions in operation manual.

The raiser respectively positioner is exclusively responsible for the safety of the system and equipment where the unit will be integrated.

During installation or maintenance all general and also all country- and application-specific safety rules and standards must be observed.

If the device is used in processes, where a failure or faulty operation could damage the system or injure persons, appropriate precautions to avoid such consequences must be taken.

1.2. Use according to the intended purpose

The unit is intended exclusively for use in industrial machines, constructions and systems. Non-conforming usage does not correspond to the provisions and lies within the sole responsibility of the user. The manufacturer is not liable for damages which has arisen through unsuitable and improper use.

Please note that device may only be installed in proper form and used in a technically perfect condition (in accordance to the technical specifications). The device is not suitable for operation in explosion-proof areas or areas which are excluded by the EN 61010-1 standard.

1.3. Installation

The device is only allowed to be installed and operated within the permissible temperature range. Please ensure an adequate ventilation and avoid all direct contact between the device and hot or aggressive gases and liquids.

Before installation or maintenance, the unit must be disconnected from all voltage-sources. Further it must be ensured that no danger can arise by touching the disconnected voltage-sources.

Devices which are supplied by AC-voltages, must be connected exclusively by switches, respectively circuit-breakers with the low voltage network. The switch or circuit-breaker must be placed as near as possible to the device and further indicated as separator.

Incoming as well as outgoing wires and wires for extra low voltages (ELV) must be separated from dangerous electrical cables (SELV circuits) by using a double resp. increased isolation.

All selected wires and isolations must be conform to the provided voltage- and temperature-ranges. Further all country- and application-specific standards, which are relevant for structure, form and quality of the wires, must be ensured. Instructions about the permissible wire cross-sections for wiring are described in the chapter “

Technical Specifications”.

Before first start-up it must be ensured that all connections and wires are firmly seated and secured in the screw terminals. All (inclusively unused) terminals must be fastened by turning the relevant screws clockwise up to the stop.

Overvoltages at the connections must be limited to values in accordance to the overvoltage category II.

For placement, wiring, environmental conditions, as well as shielding and earthing/grounding of the supply lines, the general standards of industrial automation industry and the specific shielding instructions of the manufacturer are valid. Please find all respective hints and rules on www.motrona.com/download.html --> “[General EMC Rules for Wiring, Screening and Earthing]”.

1.4. Cleaning, Maintenance and Service Notes

To clean the front of the unit please use only a slightly damp (not wet!), soft cloth. For the rear no cleaning is necessary. For an unscheduled, individual cleaning of the rear the maintenance staff or assembler is self-responsible.

During normal operation no maintenance is necessary. In case of unexpected problems, failures or malfunctions the device must be shipped back to the manufacturer for checking, adjustment and reparation (if necessary). Unauthorized opening and repairing can have negative effects or failures to the protection-measures of the unit.

2. Compatibility Hint

This product has been designed as a replacement of the following two units:

- GV202 (dual splitter with TTL Input)
- GV203 (dual splitter with HTL input)

The new GV204 model is fully compatible to the previous models with all functions, connections, dimensions and technical specifications. Merely the successor model provides an additional DIL switch to set the input format to either TTL or HTL level, which allows to replace both parent models by just one new model.

Moreover, GV204 provides a few technical upgrades (e.g. higher frequencies), resulting in increased quality without affecting the compatibility.

3. Application

The GV 204 splitter has been designed for proper and trouble-free splitting of encoder signals to two target units. Where signals have to be distributed to more targets, it is easy to cascade several units (or to use a multi-splitter like GV470)

If applicable, the unit can at the same time operate as a level converter between TTL/RS422 levels and HTL (10 ... 30 V) levels.

It is possible to use only inputs A, B, Z and leave the inverted inputs /A, /B, /Z unconnected (single-ended signals with HTL level)

When all signals A, /A, B, /B, Z, /Z are available, GV 204 will accept all industrial impulse formats and levels like RS422, TTL-differential, HTL-differential).

The outputs provide all signals A, /A, B, /B, Z, /Z, even when the inverted signals are not available on the input site. The output signal level is individually selectable to 5 V or to 10 ... 30 V, by corresponding DIL switch setting.

4. Block Diagram

The subsequent block diagram shows all essential circuit details of a GV204 unit:

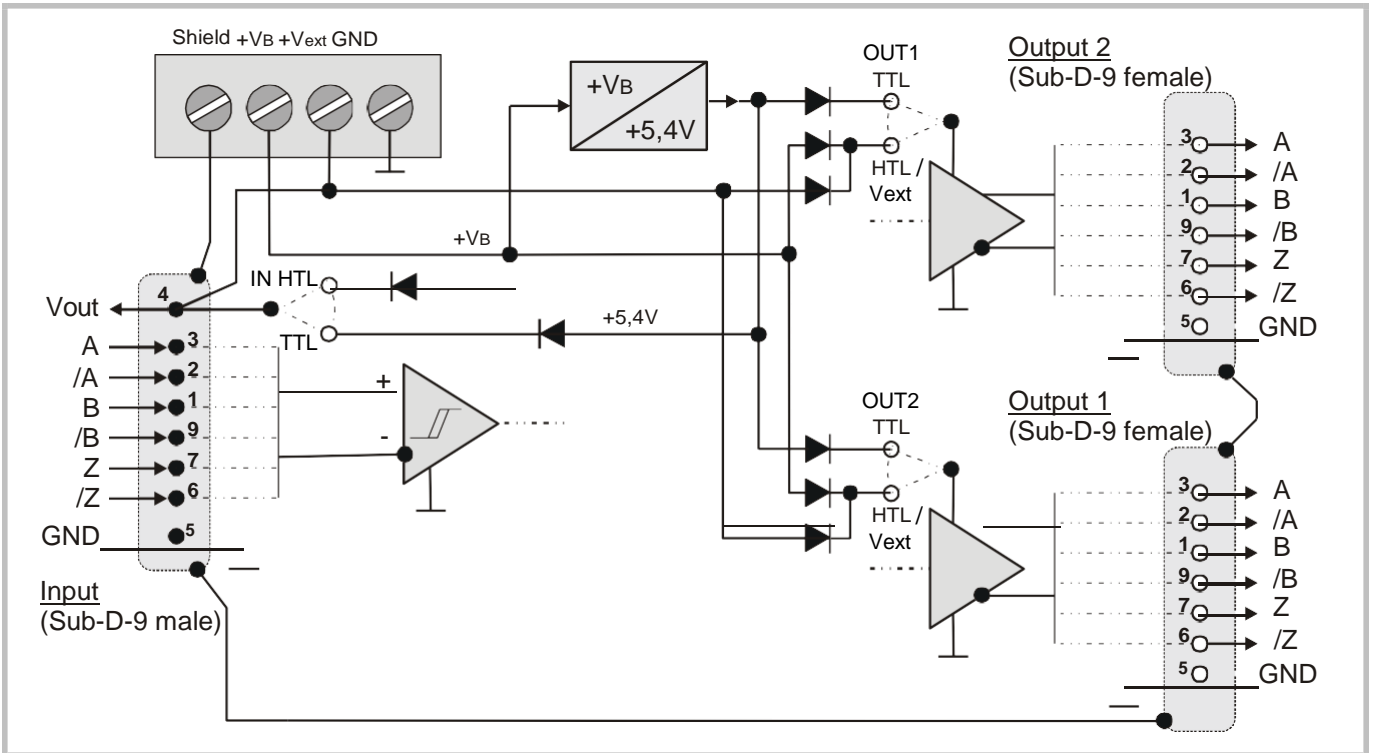

5. Power Supply

5.1. Supply via +V_B from an unstabilized 10 ... 30 VDC source

In general, the unit is supplied with an unstabilized DC voltage of 10 ... 30 VDC, using the screw terminals +V_B and GND. In this case pin 4 of the input SUB-D-connector will also provide a +5 V auxiliary output for encoder supply (max. 150mA).

5.2. Supply via +V_{ext} from a stabilized +5 VDC source

By using the screw terminals +V_{ext} and GND, the unit accepts also stabilized supply from a +5 VDC source.

Instead of the screw terminals, the unit can alternatively be powered by using Pin 4 (+ 5 V) and Pin 5 (GND) of the 9-pin input connector (e.g. when the input comes from the encoder simulation of a drive which is also intended to supply the splitter)..



- Units supplied with 5 V only are unable to generate output levels higher than 5 V.
- In case of a 5 VDC supply via +V_{ext}. and desired TTL output levels, however, the respective DIL switch setting must be "HTL / V_{ext}".

The screw terminal marked "Shield" connects the metallic housings of the SUB-D-connectors only. Depending on individual needs for earthing and screening, it can remain unconnected or tied to earth or to unit GND.



- For technical reasons no reverse polarity protection is available when the unit is supplied with +5V only. Wrong polarity misconnection of the 5 VDC power may cause serious damage to the unit.
- Screw terminal "+V_{ext}" and pin 4 of the 9-position input connector are galvanically connected inside the unit. It is therefore not allowed to apply different potentials to these two positions

6. Impulse Inputs

The input impulses must be applied to the 9-position SUB-D-connector marked "Input" (male connector on unit site). The pin assignment is shown in the block diagram and is also printed to the top side of the unit.

The 6-position DIL switch on top of the unit provides setting of the desired input characteristics. With most of all practical applications one of the following two configurations will be suitable:

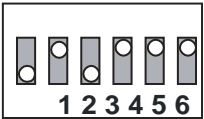
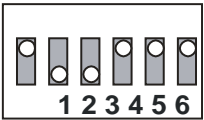
Switch Setting	Acceptable Signal Levels	Required Input Signals	Aux. Output Pin 4 (Encoder Supply)
	RS422 (Diff. >1V) TTL (5 V) HTL (10 ... 30 V)	Differential signals A, /A, B, /B, Z, /Z (inverted signals are "must")	+5,4 V (respectively $V_{ext.}$ *)
	HTL (10 ... 30 V)	Single-ended signals A, B, Z (no inverted signals required)	+ V_B - 1,4 V (respectively $V_{ext.}$ **)

Other switch positions than shown above are reserved for special applications and must only be used upon advice of motrona.

- *) Where for encoder supply a voltage higher than 5.4 V should be required, please apply an appropriate voltage to terminal + $V_{ext.}$
- ***) Where for encoder supply a voltage higher than + V_B should be required, please apply an appropriate voltage to terminal + $V_{ext.}$

7. Impulse Outputs and Output Levels

The output signals are available on the two SUB-D-connectors marked "OUT1" and "OUT2" (female connectors on unit site). The pin assignment is shown in the block diagram and is also printed to the top side of the unit.

The four-position DIL-Switch provides individual setting of the output levels for each of the two output channels. At any time also the inverted signals will be available at the output, even when no inverted signals appear at the input.

OUT1: TTL	OUT1: HTL / V _{ext}	OUT2: TTL	OUT2: HTL / V _{ext}

With output format "TTL" and powering via V_B the output level is always 5 V.

With output format "HTL / V_{ext}" the output level approx. corresponds to the supply voltage V_B*).

When terminal +V_{ext} receives a voltage higher than the power supply V_B, resp. the unit is powered via the +V_{ext} input, the output level will correspond to +V_{ext} *).



- Units supplied with 5 V only are unable to generate output levels higher than 5 V.
- In case of a 5 VDC supply via +V_{ext}. and desired TTL output levels, however, the respective DIL switch setting must be "HTL / V_{ext}", because the setting "TTL" only works with +V_B powering and internal TTL level generation.

*) Voltage drop is about 1.4 V

8. Dimensions

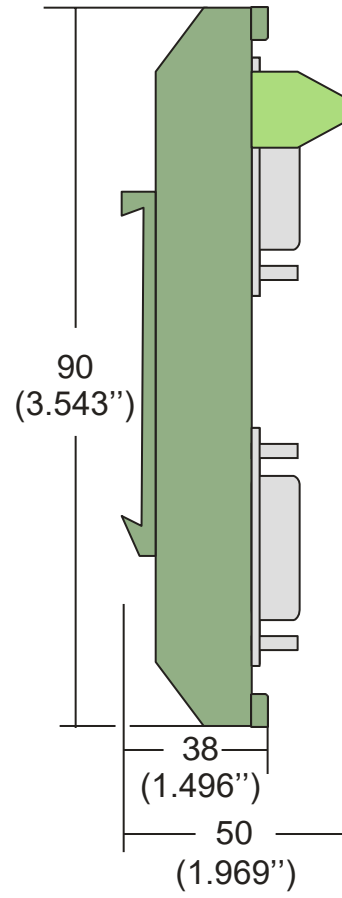
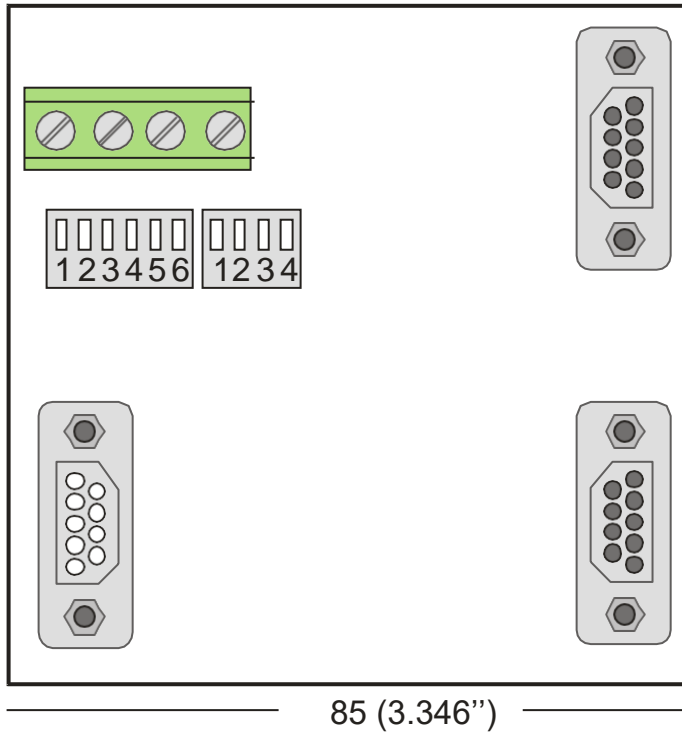

9. Technical Specifications

Power supply:	Input voltage (selective): Protection circuit: Ripple: Consumption: Connections:	5 ... 30 VDC (at pin Vext) or 10 ... 30 VDC (at pin VB) reverse polarity protection ≤ 10 % at 24 VDC approx. 5... 50 mA, unloaded (depends on input voltage) screw terminal, 1.5 mm ² / AWG 16
Encoder supply	Output voltage (selective): Output current: Connections:	5.3 VDC or 5 ... 30 VDC or 10 ... 30 VDC max. 150 mA SUB-D connector (male), 9-pin
Frequency inputs:	Signal levels: Channels: Frequency: Connections:	TTL / RS422 (differential voltage > 1 V) or HTL (LOW: 0 ... 3.5 V, HIGH: 10... 30 V) asymmetrical A, B, Z respective symmetrical A, /A, B, /B, Z, /Z max. 750 kHz (RS422 / TTL differential) max. 350 kHz (HTL) SUB-D connector (male), 9-pin
Frequency outputs:	Number of outputs Signal levels: Channels: Output current: Output circuit: Signal propagation delay: Connections:	2 either TTL (5 V) or HTL (≅ power supply voltage minus approx. 1.4 V) A, /A, B, /B, Z, /Z max. 30 mA per output push-pull approx. 700 ns SUB-D connectors (female), 9-pin
Housing:	Material: Mounting: Dimensions (w x h x d): Protection class: Weight:	plastic 35 mm top hat rail (according to EN 60715) 85x90x50mm / 3.346x3.543x1.968inch IP20 approx. 120 g
Temperature range:	Operation: Storage:	0 °C ... +45 °C / +32 ... +113 °F (not condensing) -25 °C ... +70 °C / -13 ... +158 °F (not condensing)
Failure rate:	MTBF in years:	225.7 a (long-term usage at 60 °C / 140 °F)
Conformity & standards	EMC 2004/108/EC: Guideline 2011/65/EU:	EN 61000-6-2, EN 61000-6-3, EN 61000-6-4 RoHS-conform